

## SCHEDA TECNICA

### Bottiglia PET 100 cl - BVS30

#### CARATTERISTICHE TECNICHE

- TIPO MATERIALE:	Resina PET barrierata
- PESO:	50-50,5 gr
- APPLICAZIONE:	Enologia
- IMBOCCATURA:	BVS30
- TIPO CHIUSURA:	Starvin 30x60
- ALTEZZA BOTTIGLIA:	297,35 mm +/- 2
- LARGHEZZA BOTTIGLIA:	81 mm +/- 0,75
- DISEGNO TECNICO:	202100430_08

#### IMBALLAGGIO

- PALLET LEGNO:	cm 100x120
- QUANTITÀ PALLET:	> 6 strati > 1.176 pz > 7 strati > 1.372 pz
- TRASPORTO:	automezzo bilico > 26 pallet granvolume > 30 pallet

*Nota: I valori indicati sono da considerarsi orientativi in quanto potenzialmente variabili in base alle caratteristiche della materia prima PET e/o delle caratteristiche dell'impianto di produzione e/o delle condizioni specifiche di applicazione e/o delle condizioni ambientali.*

ISO A2	REV.	DATE	DESCRIPTION	BY
	*	*		*

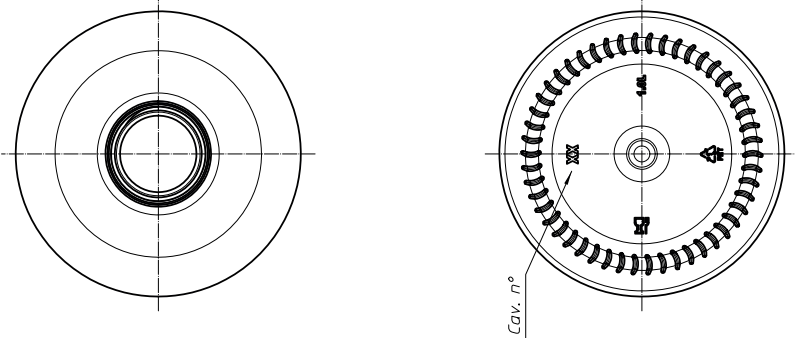
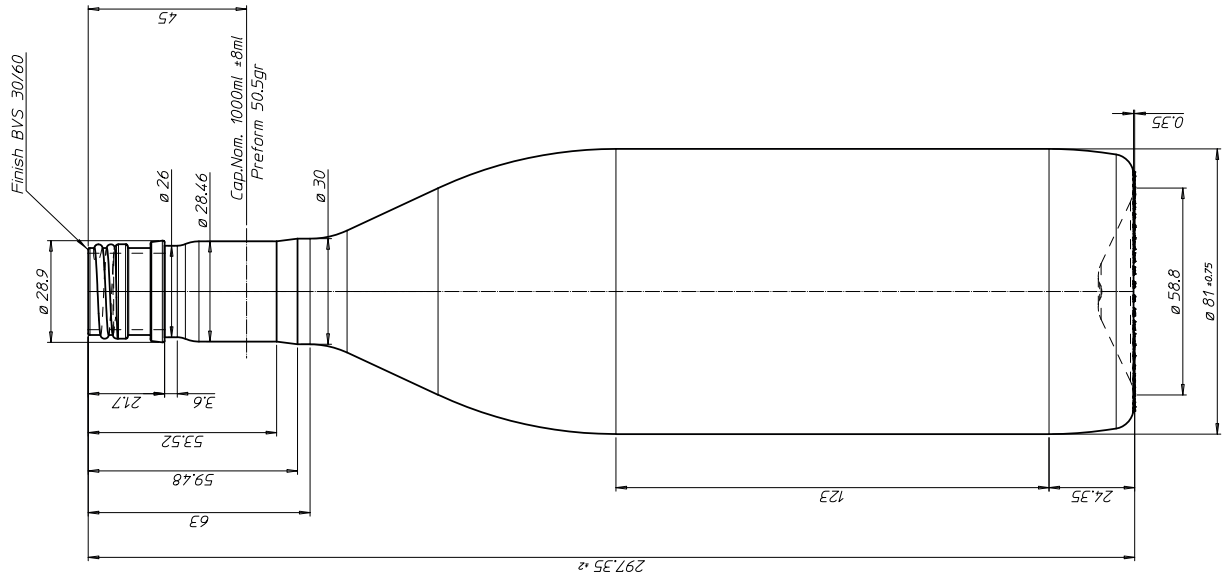

MATERIAL <b>PET</b>	QTY. REQUIRED *	HARD. TREAT. *	COATING SURF. *
<p><b>SIMEX</b> Modulas Division          Via B. Inghi. e D. An. Onof. S.          10125 - 071 750021 Italy          Tel. +39 071 750021          Fax. +39 071 7500958          www.simexitalia.it</p>			
<p>THIS DRAWING IS THE PROPERTY OF SIMEX S.p.A.          ALL RIGHTS ARE RESERVED AND WHETHER THE DRAWING          HAS OR HAS NOT BEEN REGISTERED IN THE PATENT OFFICE,          NO PART THEREOF IS TO BE REPRODUCED OR TRANSMITTED          IN ANY FORM OR BY ANY MEANS, WITHOUT THE WRITTEN          PERMISSION OF SIMEX S.p.A.</p>			
DATE 08.11.21	SCALE 1:1	TITLE 3000 Bollaigh 1000ml 1/1r	METRIC
DRAWN C.O.	CHECKED P.L.	DESCRIPTION Disegno Preliminare	DIMENSIONS ARE IN MILLIMETERS
APPROVED C.P.	SHEET 1 OF 1	DRAWING NO. 01f.252_06.10.21	FILE NO. 202100430_08

Last update: 01.12.2021