

## SCHEDA TECNICA

### Bottiglia PET 25 cl ST BERICAP

#### CARATTERISTICHE TECNICHE

- TIPO MATERIALE:	Resina PET
- COLORE:	Clear o White
- PESO:	23 gr
- APPLICAZIONE:	Bevande-Succhi-Prodotti lattiero caseario
- IMBOCCATURA:	BERICAP 3/P mm 38
- ALTEZZA BOTTIGLIA:	140,7 mm +/- 1
- LARGHEZZA BOTTIGLIA:	56 mm +/-0,4
- DISEGNO TECNICO:	201500097_08B

#### IMBALLAGGIO

- PALLET LEGNO:	cm 100x120
- QUANTITÀ CARTONE AMERICANO:	> 2.300 pz
- TRASPORTO:	motrice > 28-32 pallet bilico > 52 pallet granvolume > 60 pallet

*Nota: I valori indicati sono da considerarsi orientativi in quanto potenzialmente variabili in base alle caratteristiche della materia prima PET e/o delle caratteristiche dell'impianto di produzione e/o delle condizioni specifiche di applicazione e/o delle condizioni ambientali.*

ISO A3	REV.	DATE	DESCRIPTION	BY
	*	*	*	*

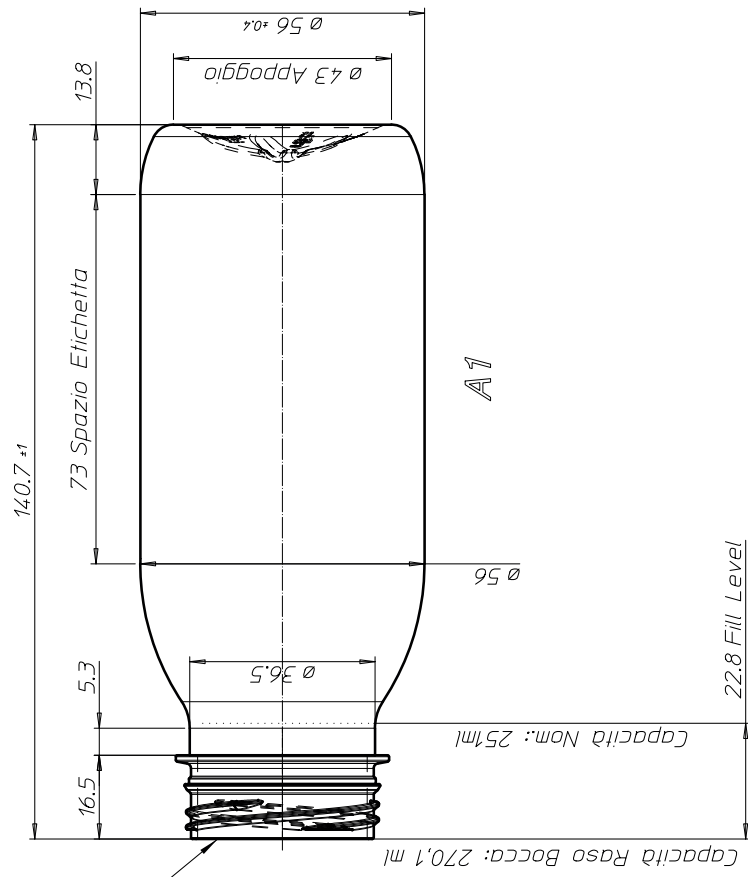

Finish: Bericap PT38

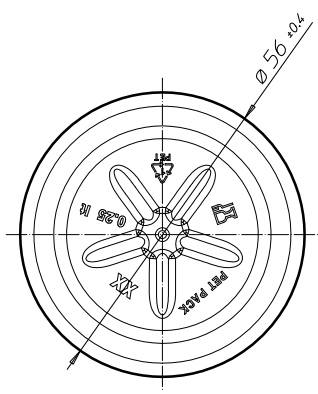

B1

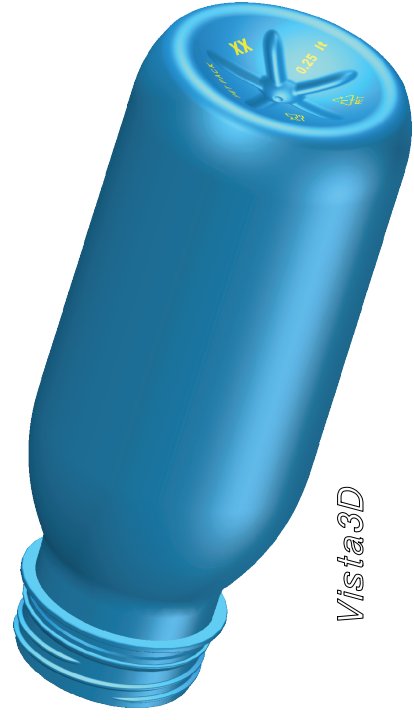

Vista3D

MATERIAL <b>PET</b>	QTY. REQUIRED <b>1</b>	HARD. TREAT. *	COATING SURF. *
 <p><b>SIMEX</b> srl Moulds Division Via Biaggi e Di Asola, 5 60025 - S. Oreste (AN) Italy Tel. +39 071 750021 Fax. +39 071 7501858 www.simexitaly.it</p>		<p>THIS DRAWING IS THE PROPERTY OF SIMEX srl. ALL RIGHTS ARE RESERVED AND NEITHER THIS DRAWING NOR ANY INFORMATION IT CONTAINS IS TO BE COPIED, REPRODUCED, DISCLOSED TO OTHERS OR USED WITHOUT THE PRIOR WRITTEN PERMISSION FROM SIMEX srl.</p>	
DRAWN <i>l.p.</i>	DATE <b>20.03.12</b>	SCALE <b>1:1</b>	TITLE <i>Bott. 250ml Finish Bericap PT 38</i>
CHECKED <i>p.l.</i>	DATE *	SHEET <b>1</b> OF <b>1</b>	DESCRIPTION <i>Disegno Esecutivo</i>
APPROVED <i>C.P.</i>	DATE *	JOB NO. <b>201500097</b>	DRAWING NO. <b>201500097_08B</b>
			FILE NO. *

Last update: 20.10.2020