

SCHEDA TECNICA Bottiglia PET 50 cl KF



CARATTERISTICHE TECNICHE

- TIPO MATERIALE:	Resina PET
- COLORE:	Clear o White
- PESO:	24 gr
- APPLICAZIONE:	Prodotti lattiero caseario
- IMBOCCATURA:	A&F mm 38
- ALTEZZA BOTTIGLIA:	196,7 mm +/- 2
- LARGHEZZA BOTTIGLIA:	66 mm +/-0,75
- DISEGNO TECNICO:	201600097_08

IMBALLAGGIO

- PALLET LEGNO:	cm 100x120
- QUANTITÀ CARTONE AMERICANO:	> 1.200 pz
- TRASPORTO:	motrice > 28-32 pallet bilico > 52 pallet granvolume > 60 pallet

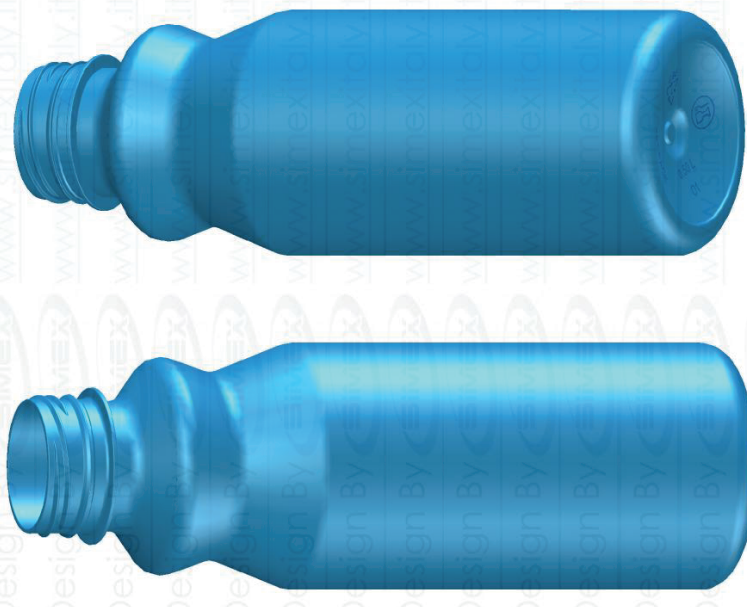
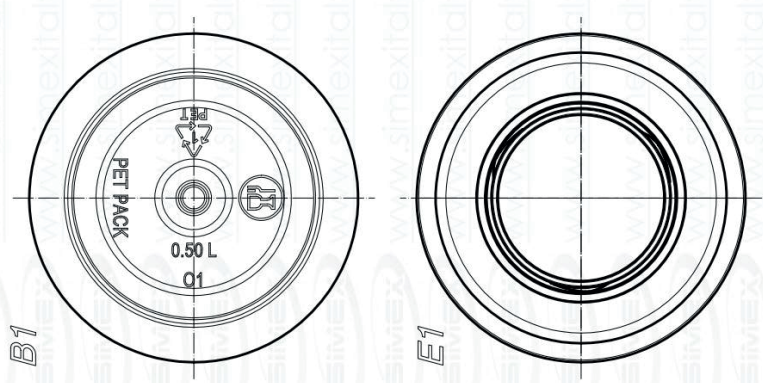
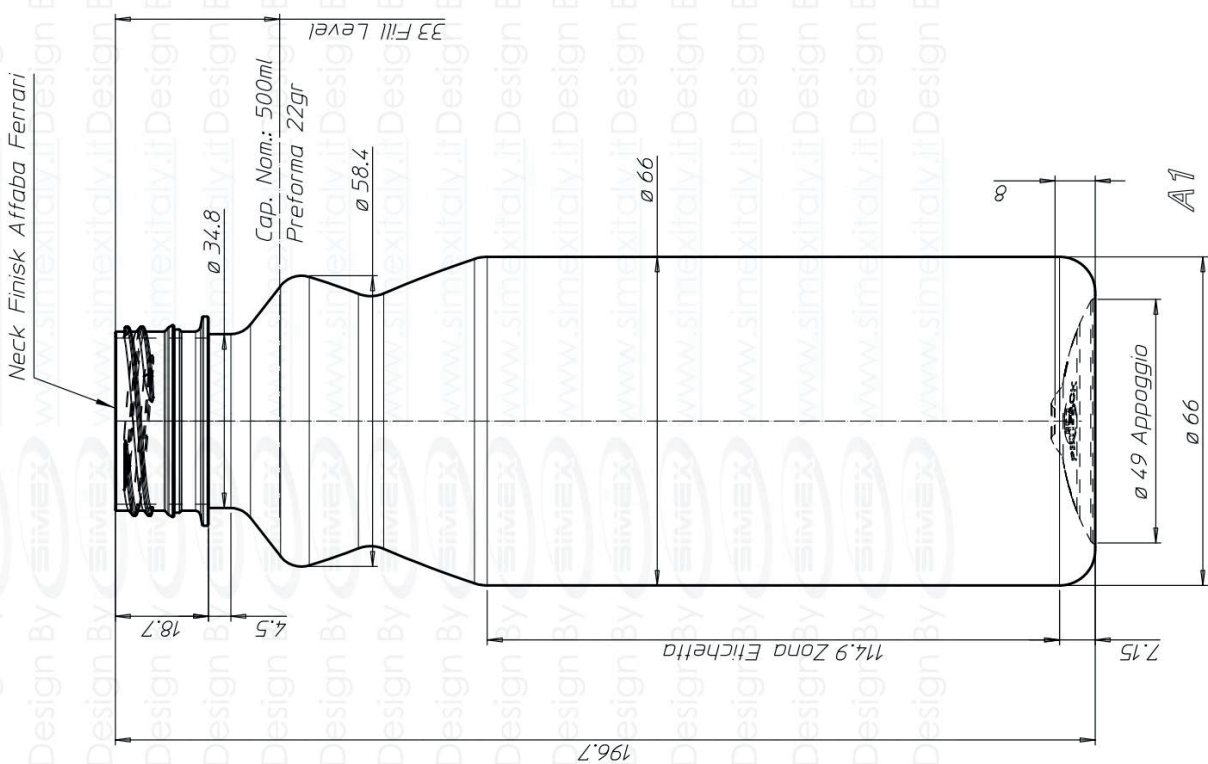
Nota: I valori indicati sono da considerarsi orientativi in quanto potenzialmente variabili in base alle caratteristiche della materia prima PET e/o delle caratteristiche dell'impianto di produzione e/o delle condizioni specifiche di applicazione e/o delle condizioni ambientali.

ISO A3	REV.	DATE	DESCRIPTION	BY
			Viste 3D	
				
				
				
MATERIAL PET		QTY. REQUIRED 1	HARD. TREAT. *	COATING SURF. *
		<p>SIMEX srl Moulds Division Via Biagi e D'Ancona, 5 60025 Loreto (AN) Italy Tel. +39 071 7500214 Fax. +39 071 7501968 www.simexitalia.it</p>		
DRAWN <i>p.l.</i>	DATE 12.07.13	SCALE 1:1	<p>THIS DRAWING IS THE PROPERTY OF SIMEX s.r.l. ALL RIGHTS ARE RESERVED AND NEITHER THIS DRAWING NOR ANY INFORMATION IT CONTAINS IS TO BE COPIED, REPRODUCED, DISCLOSED TO OTHERS OR USED WITHOUT THE PRIOR WRITTEN PERMISSION FROM SIMEX s.r.l.</p>	
CHECKED <i>p.l.</i>	DATE *	SHEET 1 OF 1	<p>METRIKO DIMENSIONS ARE IN MILLIMETERS</p> 	
APPROVED <i>c.p.</i>	DATE *	JOB NO. 2016000097	<p>TITLE Bottiglia 500ml</p> <p>DESCRIPTION Disegno preliminare</p> <p>DRAWING NO. 2016000097_08A</p> <p>FILE NO. *</p>	

Last update: 22.06.2016